

DST-777S, DST-777D SETPOINT TEMPERATURE CONTROLS



INSTALLATION AND OPERATING INSTRUCTIONS

APPLICATION

DST-777 series controls are microprocessor-based electronic one or two stage setpoint temperature controls, designed to provide one or two on/off controls (Single-Pole Double-Throw (SPDT) relay outputs) for residential/commercial heating, cooling, air conditioning and refrigeration applications.

The DST-777 is equipped with a Dual Digital display with backlit that provides a constant readout of the sensor temperature and setpoint simultaneously as well as the other programmed settings. The front buttons allow the user to easily and accurately select the setpoint temperature, differential and heating/cooling mode of the operation. Unique **QuickSet** feature allows instant setpoint adjustment without entering programming mode. This reliable and versatile control has a very wide setpoint range, an adjustable differential and time delay that makes it applicable in many different applications. The single stage models have Pulse Width Modulation (PWM) control logic to prevent overshoots and undershoots in slow responding systems with large thermal mass such as pools or slabs. A sensor probe P-01 is supplied with the control. This solid state temperature sensor probe can be extended up to 500 feet.

FEATURES

- Reliable Digital Electronic Accuracy
- QuickSet** feature allows instant setpoint adjustment without entering programming mode
- Easy-to-Read Dual Digital Display with backlit which provides constant readout of sensor temperature and setpoint simultaneously, functional status and control settings. It also allows precise setpoint and differential settings
- Simple and user-friendly programming of setpoint temperature, differential and cooling/heating modes
- EEPROM memory retains control settings in the event of a power failure
- Wide adjustable setpoint with temperature range from -40 to 240°F and differential from 1 to 100°F. This enables the user to optimize the system performance for any applications. A tighter differential can be achieved (eg. 1°F or 1°C) than conventional electromechanical controls
- Advanced PWM (Pulse Width Modulation) Control to achieve high control accuracy on single stage models
- Choice of one or two stage models
- One or two SPDT relay outputs. Model: DST-7772(two stage) can handle one or two sensor inputs with two setpoints. When using two sensor inputs, each setpoint can be corresponding to one relay output. (Two units in one control)
- LED indicates output relay status
- Adjustable Anti-Short Cycle Delay to ensure the output relay remains off for up to 20 minutes. This would avoid unnecessary hard start and equipment wear
- Selectable Fahrenheit or Celsius scales
- Selectable Heat or Cool modes
- Maximum and minimum memory for sensor temperature
- Lockout mode to prevent tempering by unauthorized personnel
- Remote temperature sensor which can be extended to 500 ft.
- Sensor failure and out of range indication
- Easy installation and setup
- Fast sampling rate (1 sec.) Of the sensor temperature for instant control action
- Easy-Connect Screwless Terminals for sensor connection
- Backlit option: Auto (30 sec.)/OFF/ON
- Power surge protection

SPECIFICATIONS

- Setpoint Temperature Range: -40 to 240°F (-40 to 116°C)
- Temperature Display Resolution: 0.1°F/0.1°C
- Differential Adjustment: 1 to 100°F (1 to 38°C)
- Anti-Short Cycle Delay: 0 to 20 min. (1-Minute increments)
- PWM Cycle Length: 30 to 1500 sec. (10-Second Increments)
- PWM Differential: 3 to 50°F (2 to 25°C)
- Accuracy: ±1°C / ±1°F
- Input: 10K ohm thermistor probe (included); P-01 (designed for strap on a pipe or insert into a temperature well)
- Temperature sampling rate: 1 second
- Operating Voltage: 120 or 240 VAC, 50/60Hz
- Relay: 1 or 2 x SPDT, 120VAC, Full Load 16A, 1Hp
- Enclosure: Flame Retardant Plastic 94V0
- Weight: 3.0 lbs
- Dimension: 6 3/8"(W) x 6 5/8"(H) x 2 3/4"(D)

P-01 Sensor Probe:

- Sheath: Copper
- Lead: 10' of 20 AWG heat resistance wire
- Dimension: 3/8" OD x 13/16" length
- Operating range: -60 to 255°F (-50 to 125°C)
- Sensor: 10K ohm @ 77°F (25°C ± 1%) thermistor
- Can be strapped on a pipe or inserted into a temperature well

Models:

- DST-777S Single Stage Setpoint Temperature Control
- DST-777D Single Stage Setpoint Temperature Control with 2 outputs

CAUTION!

- To prevent electrical shock hazard, disconnect power supply before installing.
- All wiring must comply with national and local electrical codes, ordinances, and regulations.
Never connect the load terminals to a load that takes more current than the amount listed for the relay in the electrical ratings.
- Azel Technologies is not responsible for damages resulting from misuse of its products.
- 12-18 gauge wire is recommended for 120 VAC connections;
18 gauge or larger wire is recommended for sensor connections.
- This literature is provided for informational purposes only.

MOUNTING

Mount the DST-777 controller to a suitable surface. Slotted keyholes and standard holes are provided for mounting purposes.

MOUNTING THE SENSOR:

The sensor P-01 can be extended up to 500 with conventional 18 gauge wire (or larger to keep additional resistance to a minimum). It is designed to strap on a pipe or insert onto a temperature immersion well.

Sensors should be strapped to the pipe with cable tie. The flat side of the sensor should be resting on the pipe. In addition, they should be covered with a layer of insulation to minimize the effects of ambient temperature for a more reliable temperature reading.

The sensor P-01 can also be insert onto a 3/8"(10mm) or 1/2"(12.7mm) ID temperature well.

Note: Do not run sensor wires parallel to other electrical wiring or telephone wires. In case there is strong source of electromagnetic interference, twisted pair 20AWG wire is recommended.

ROUGH-IN WIRING

Loosen the screws on the top and bottom of the enclosure and remove the wiring covers by swinging them away from the base (grey color) with the edges of the covers as pivot (see Figure 1).

The base has standard 7/8" (22mm) knockouts which accept common wiring hardware and conduit fittings. Before removing the knockouts, check the wiring diagrams and use the chamber with common voltages.

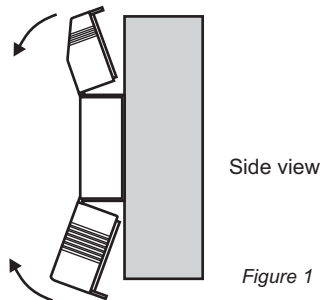

OPERATION

Liquid Crystal Display

In normal operating mode, the upper LCD display the current sensor temperature and the lower LCD display the setpoint temperature. The display is also used with the Up Arrow and Down Arrow buttons to adjust the setpoint temperature, differential and heating/cooling modes of the operation.

LCD Blue Backlit Options: set by slide switch on the front panel

- ON - backlit is turned on.
- OFF - backlit is turned off.
- Auto - backlit is turned on for 30 secs when any button is pressed.

L.E.D. SYSTEM STATUS INDICATION LIGHTS:

RED light indicates that the SPDT relay output is energized.

Heating Mode and Cooling Mode: set by keypad

Heating Mode (factory setting):

The control output will turn on when the sensor temperature falls to the setpoint temperature minus the differential amount. The control output will turn off when the sensor temperature reaches the setpoint temperature. For example, if setpoint = 68F, Differential = 3F, then output is on at 65F and off at 68F. In other words, when the heating mode is chosen, the differential is below the setpoint. The relay will de-energize as the temperature rises to the setpoint. Refer to Figure 2.

Cooling Mode:

The control output will turn on when the sensor temperature rises to the setpoint temperature plus the differential amount. The control output will turn off when the sensor temperature reaches the setpoint temperature. For example, if setpoint = 75F, Differential = 2F, then output is on at 77F and off at 75F. In other words, when cooling mode is chosen, the differential is above the setpoint. The relay will de-energize as the temperature falls to the setpoint.

The control output turned on means:

From the isolated SPDT relay output, "NO" are normally open contacts which close and "NC" are normally closed contacts which open when the control output is on.

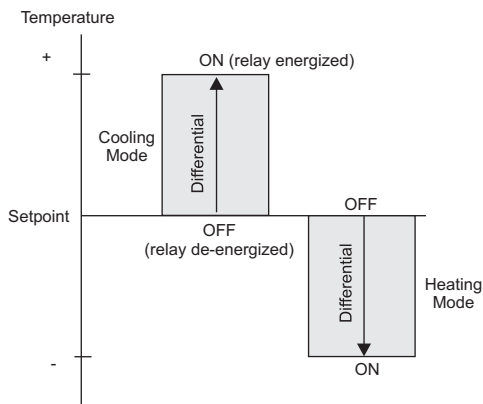

Figure 2: Operation of relay in according to Setpoint and Differential Settings for both Heating and Cooling Mode

Normal Control Mode(ON/OFF Control): Set PWM slide switch to OFF

The control outputs will turn on the equipment when there is a demand for heating or cooling. When the demand is satisfied, the control outputs will turn it off.

Pulse Width Modulation (PWM) Mode(PWM CONTROL): Set PWM slide switch to ON

The single stage models (DST-777S, DST-777D) offer optimum control by means of a Pulse Width Modulation(PWM). In PWM, the ON and OFF cycle vary depending on the difference between the sensor and setpoint temperature. The bigger difference between the sensor and setpoint temperature, the longer the relay is switched ON. When the sensor temperature approaches the setpoint temperature, the ON time become shorter and shorter. Pulse Width Modulation guarantees precise control response. This function prevents overshoots and undershoots in systems with large thermal mass (eg. slabs or pools).

Figure 3 shows the operation of relay on Heating Mode during PWM cycle:

- If the sensor temperature is half of the PWM Differential above the setpoint temperature (in this example is: 79°F (75 + 8/2), relay is OFF.
- If the sensor temperature is half of the PWM Differential below the setpoint temperature (in this example is: 71°F (75 - 8/2), relay is ON.
- If the sensor temperature is between 71°F and 79°F, PWM is in action. When the sensor temperature crosses the rising slope of the triangle wave generated by the control, relay is turned ON during the shaded region. When the sensor temperature passes the falling slope of the triangle wave, the relay is turned OFF during the unshaded region.
- The pulse width (the relay ON time within one cycle) is modulated in according to how far the sensor temperature deviates from the setpoint temperature.
- If sensor temperature is the same as the setpoint temperature, the pulse width is half (50%) of the cycle length.
- If the sensor temperature is higher than the setpoint temperature, the pulse width allows shorter period of ON time
- If the sensor temperature is lower than the setpoint temperature, the pulse width allows longer period of ON time.
- If PWM mode is selected, the minimum time delay is disabled.
- The principle of operation on Cooling Mode is the same with the shaded and white area reversed in Figure 3.

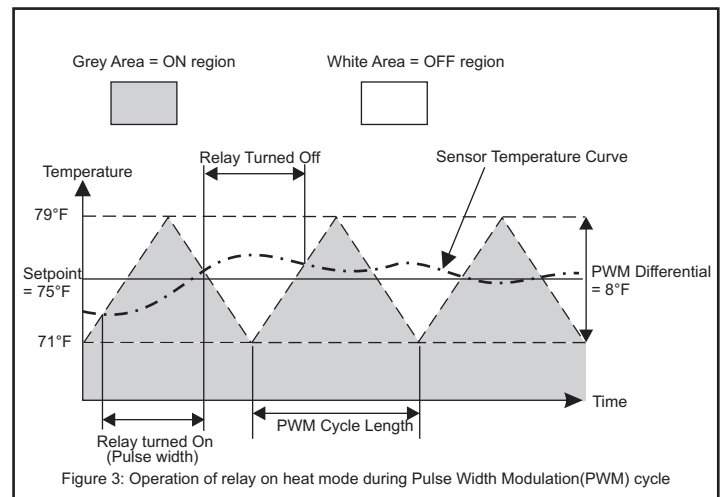

Figure 3: Operation of relay on heat mode during Pulse Width Modulation(PWM) cycle

Anti-Short Cycle Delay: set by keypad

Anti-Short Cycle Delay can be set to ensure the output relay remains off for up to 20 minutes (default is 0 mins) after relay is de-energized. This is adjustable from 0 to 20 min with 1 minute increments. In other words, this function establishes the minimum time that the output relay remains de-energized before the next on-cycle. It does not allow the output relay to re-energize until the programmed time delay has elapsed. The delay is activated when the control is first turned on, but can be skipped within the first 3 seconds by pressing the "SET" key once and go to normal operating mode (Note: SET key at this stage will not perform any other function except terminating the time delay). **Anti-Short Cycle Delay is available only when PWM is off.**

When the delay is activated, the Upper LCD shows the current temperature and the lower LCD shows blinking "AC" which stands for Anti-Cycle. Also, in case there is a demand for heating/cooling, the red LED for relay output will be blinking indicating that anti-cycle feature prevent relay from energizing.

WIRING THE CONTROL

Refer to Figure 4 for typical wiring connections for DST-777S and Figure 5 for DST-777D. Do not use wire larger than 12 AWG as jumper between terminal blocks (eg. "120V" and "C")

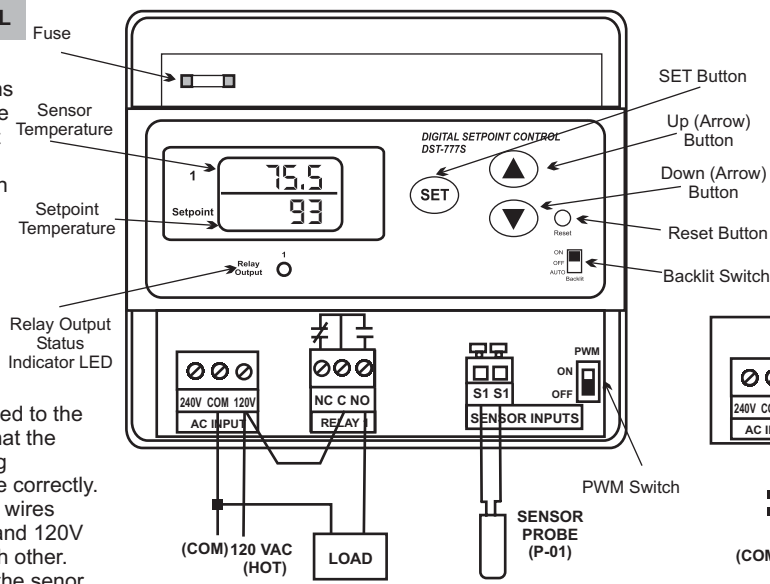

Figure 4: Typical Wiring Diagram for DST-777S with 120Vac Load

Terminal Representations:

240V is the hot of the 240Vac line voltage
COM is the neutral or ground of the line voltage
120V is the hot of the 120Vac line voltage

RELAY 1/RELAY 2

NC is Normally Close of SPDT switch and opens when the relay is energized
C is Common of the SPDT switch
NO is Normally Open of the SPDT switch and closes when the relay is energized

SENSOR INPUT

S1 S1 are the input terminals for sensor probe P-01

Checkout

- Before power is applied to the control, make sure that the installation and wiring connections are done correctly. Also, ensure that the wires connecting to COM and 120V are not touching each other.
- Ensure that wires of the sensor probe are not touching each other

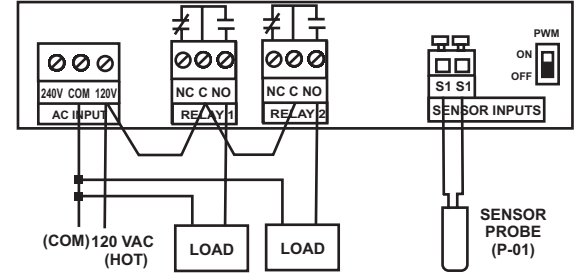

Figure 5: Typical Wiring Diagram for DST-777D with 120Vac Loads

POWER ON

All the slide switches (Backlit and PWM) should be set before the control is powered up (so the desired switch settings are scanned by the microprocessor). However if the settings on the slide switches are changed after power is supplied, press the **RESET** key so that the switch settings can be updated. When the control is powered up, the model ID is displayed. Then the control will run Anti-short cycle delay (if any) and goes into normal operating mode in which the Upper LCD will display the current sensor temperature and the Lower LCD will display the setpoint temperature.

SETTING THE CONTROLS

QuickSet Feature:

Quickset allows the user to change the setpoint temperature instantly without entering the program mode. Simply press **UP** (increase) or **Down** (decrease) key during the normal operating mode. When the **Up/Down** key is pressed, the setpoint is flashing to indicate that the setpoint value can be changed. Press the **UP/Down** button again to adjust the setpoint (press and hold for auto repeat function). Press **SET** key when finish or just walk away and it will return to normal mode after 30 seconds.

Program Mode:

General Note:

- Press and hold the **Up Key** or **Down Key** to change the value continuously (auto repeat function).
- To return to normal operating mode from the program mode, press and hold the **SET** key for 3 seconds. However, the system also return to normal operating mode if no key is pressed for 30 seconds.
- During the program mode, each time **SET** key is pressed, the data will be saved into the EEPROM and advance to the next setting (parameter). If no change of value is required, just press **SET** key once to go to the next step (parameter).





Programming Steps for Normal Control Mode (ON/OFF Control)

Note: Set PWM slide switch to OFF

Steps	Procedures	Description	LCD Display
Step 1	To start programming, press the SET key for 3 seconds to access the Fahrenheit/Celsius mode. The lower LCD display will show the current status, either F for degrees Fahrenheit or C for degrees Celsius. This annunciator will be flashing. Then press either Up or Down key to toggle between the F or C scales.	Fahrenheit or Celsius Scale The default value is F	
Step 2	Press SET key again to access the setpoint mode. The lower LCD will display the current setpoint (flashing) and the upper LCD will display S1 annunciator. Then press either the Up key to increase or the Down key to decrease the setpoint to the desired setting. ** Please note that this value as well as all the temperature related value are in degree Fahrenheit as set in step 1.	Setpoint Temperature Default setting is: 75F	
Step 3	Press SET key again to access the differential mode. The lower LCD will display the current differential (blinking) and the upper LCD will display dF1 annunciator. Then press either the Up key to increase or the Down key to decrease the differential to the desired setting.	Differential Temperature Default setting is: 1F	
Step 4	Press SET key again to access the heating or cooling mode. The upper LCD will display the current mode, with flashing annunciator, either H1 for heating or C1 for cooling. Then press either the Up key or the Down key to toggle between the C1 or H1 operation.	Cooling or Heating Default setting is: H1	
Step 5	Press SET key again to access the Anti-Short Cycle time delay. The lower LCD will display the current time delay (blinking), in minute and the upper LCD will display AC1 . Then press either the Up key to increase or the Down key to decrease the delay to the desired setting. The increment is in 1 minute. Press SET key again to go back to normal operating mode.	Anti-Short Cycle time delay Default is: 0 minutes	

Programming Steps for PWM Control Mode

Note: Set PWM slide switch to ON

Steps	Procedures	Description	LCD Display
Step 1	To start programming, press the SET key for 3 seconds to access the Fahrenheit/Celsius mode. The lower LCD display will show the current status, either F for degrees Fahrenheit or C for degrees Celsius. This annunciator will be flashing. Then press either Up or Down key to toggle between the F or C scales.	Fahrenheit or Celsius Scale <i>The default value is F</i>	
Step 2	Press SET key again to access the setpoint mode. The lower LCD will display the current setpoint (flashing) and the upper LCD will display S1 annunciator. Then press either the Up key to increase or the Down key to decrease the set point to the desired setting. ** Please note that this value as well as all the temperature related value are in degree Fahrenheit as set in step 1.	Setpoint Temperature <i>Default setting is: 75F</i>	
Step 3	Press SET key again to access the heating or cooling mode. The upper LCD will display the current mode, with flashing annunciator, either H1 for heating or C1 for cooling. Then press either the Up key or the Down to toggle between the C1 or H1 operation.	Cooling or Heating <i>Default setting is: H1</i>	
Step 4	Press SET key again to access the PWM differential mode. The lower LCD will display the current PWM differential (blinking) and the upper LCD will display PdF annunciator. Then press either the Up key to increase or the Down key to decrease the differential to the desired setting.	PWM Differential Temperature <i>Default setting is: 8F</i>	
Step 5	Press SET key again to access the PWM Cycle Length. The lower LCD will display the current PWM Cycle Length (blinking), in seconds and the upper LCD will display CyC . Then press either the Up key to increase or the Down key to decrease the delay to the desired setting. The increment is in 10 seconds. Press SET key again to go back to normal operating mode.	PWM Cycle Length <i>Default is: 300 seconds.</i>	

Review Setting Mode:

Press both **Up** and **Down** keys at the same time to review the current control settings. Then Press **Down** (or **Up**) key to scroll through the settings in the same order as Program Mode (F/C scale, Setpoint, Differential, Heating/Cooling, Anti Cycle Time Delay etc.). To exit to normal mode, press **Down** key one more time from the last setting (eg. AC1) or press both **Up** and **Down** keys at the same time. In this mode, the settings cannot be changed.

Max/Min Memory Mode:

Maximum and Minimum sensor temperature are recorded in the memory. To view the max./min. Temperature:

- From normal operating mode, press **SET** key once (eg. Just for 1 second). The upper LCD will display the maximum recorded sensor temperature and the lower LCD will display the minimum recorded sensor temperature.
- Press **SET** key once more to exit to normal operating mode.



Note: During Max/Min mode, Max/Min memory can be reset by pressing both **Up** and **Down** keys at the same time until the upper LCD displays "Clr" (means cleared). Then release the buttons to exit to normal mode.

Reset:

Press **RESET** key if the following changes are made after the control is powered up:

- Slide switch settings
- Time related parameters such as anti-cycle time delay or PWM cycle length

After reset, the control will start from the beginning and run on these new settings

Keypad Lock:

Keypad can be locked to prevent tampering by unauthorized personnel. This is done by pressing **SET**, **Up** and **Down** keys at the same time for three seconds. The word "LoC" appears on the LCD screen for 3 seconds which indicates that the keypad is locked. Then input from the keypad is disabled. Press **SET**, **Up** and **Down** keys at the same time again for another three seconds to unlock the keypad. The word "LoF" appears on the screen for 3 seconds which indicates that the keypad is enabled. Factory setting: unlock

Troubleshooting Error Messages

If the upper LCD display shows flashing "Err" and the lower LCD display shows S1, the sensor probe is short circuited.

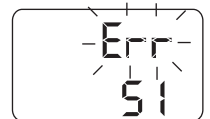

If the upper LCD display shows flashing "LLL" and the lower LCD display shows S1, the sensor probe is open circuited or the sensor temperature is out of the lower range. The relay 1 will be de-energized.

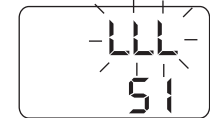

Action: Verify if the sensor temperature is open circuited or out of the lower range. If not, check for proper sensor operation by comparing it to a known ambient temperature. The easiest way is to get an Azel Technologies DS-60P digital temperature gauge which displays two P-01 sensor temperature. Connect this sensor to DS-60P and compare the reading with the good sensor.

The second way is to obtain the P-01 resistance table from the manufacturer. Then use a ohmmeter to measure the resistance across the two sensor leads and compare to the temperature reading at the sensor location.

If the upper LCD display shows flashing "HHH" and the lower LCD display shows S1, the sensor temperature is out of the upper range. The relay 1 will be de-energized.

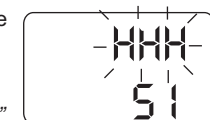

Use the same procedures as above with flashing "LLL"

AZEL TECHNOLOGIES INC.

www.azeltec.com

Please visit our website for other products

P.O. Box 53138
10 Royal Orchard Blvd.
Thornhill, Ontario, Canada L3T 7R9
Ph: 905-764-8809 Fax: 905-764-4738
Email: info@azeltec.com