

Digital Thermostat D-135ES

Go digital today with our new line of Digital Thermostats!



Azel Technologies introduces a thermostat that utilizes the latest digital technologies. The D-135ES thermostat is a stand-alone microprocessor based thermostat with large LCD display that takes the guess work out of reading the temperature. The D-135ES maintains highly accurate temperature control without the programming hassle. The thermostat is designed to control room temperature by way of on/off controlling the heating equipments. The setpoint is displayed and can be changed easily by pressing up or down arrow button. This simple to use accurate thermostat will replace most round, square or rectangular thermostats. D-135ES is environmentally safe, mercury-free which requires no leveling, so there's no hassle, and no special disposal requirements.

Replace your inaccurate, old fashioned thermostats today with more accurate digital and easy to read D-135ES.

FEATURES:

- Deluxe standard Heat Only
- Reliable Digital Electronic Accuracy
- Contains NO Mercury, environmentally safe
- Accurate Universal Replacement
- No Leveling Required
- Low Voltage (24 VAC) Systems
- Only 2 wires needed to power thermostat, no need to change battery in the future
- EEPROM (memory) for setting backup
- Adjustable differential setting
- Anti-short cycle delay
- Display in °F
- ON/OFF switch
- Built-in Digital Control System
- Modern design

SPECIFICATIONS:

- Display Format: Liquid Crystal Display(LCD)
- Power Supply: 24 Vac, 50-60Hz
- Contact Rating: 6A Resistive (3A inductive)
- Sampling Rate: 1 Minute
- Accuracy: $\pm 1^{\circ}\text{F}$
- Temperature Control Range: 40-95°F
- User selectable 3 mins. anti-short cycle delay
- Differential selection: 0.5, 1.0, 1.5, 2.0°F

WIRING DIAGRAM:

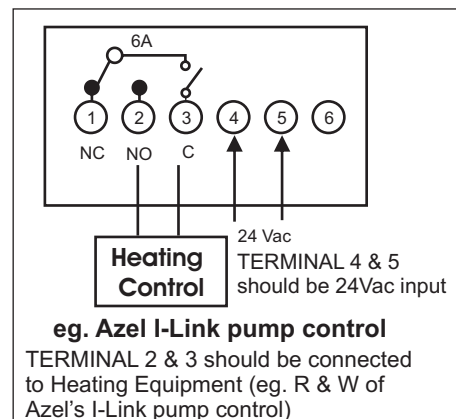

AZEL TECHNOLOGIES INC.

P.O. Box 53138
10 Royal Orchard Blvd.
Thornhill, Ontario, Canada L3T 7R9
Ph: 905-223-5567 Fax: 905-223-3778
Email: info@azeltec.com