

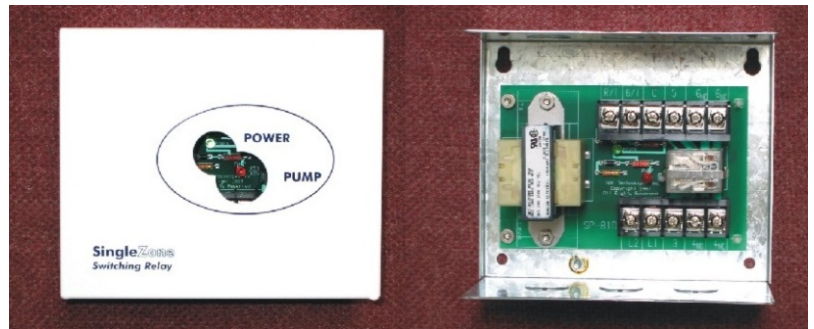

SPEEDPUMP SP-81D SINGLE ZONE SWITCHING RELAYS FOR HYDRONIC HEATING SYSTEMS

General Applications:

The SP-81S and SP-81D pump controllers are operated by low voltage thermostats or any other low voltage controllers having an SPST switching action. The SP-81S and SP-81D provide intermediate switching to permit up to two separate line voltage loads such as pumps.



Product Features and Benefits:

- * High Quality Electronics Circuit Board which Centralizes Wiring and Control Operation
- * Light display provides functional status
- * Plug-in/Removable Relays with Relay Clamps
- * High Capacity Transformer
- * Easy-Connect Terminals/Screwless Terminals for Thermostat Connections
- * Compatible with Most Digital/Mechanical Thermostats
- * CSA/NRTL (National Recognized Testing Laboratory) Certified
- * 2 Year Guarantee

MODEL	Relay Switching Action	Thermostat Current	Transformer Rating (Nominal)	Single Phase Motor Rating for Each Zone		Dimension LxWxH	Shipping Weight
SP-81D	DPDT	0.18A	120/24VAC 60Hz 15VA	1/3hp (10A)	1/2hp (10A)	6"x5"x3" (15.2CMx12.7CMx7.6CM)	2.4lbs. (1.1kg.)

SP-81D WIRING INSTRUCTIONS

1. 120VAC input: terminals L1 & L2.
2. Terminals 3 & 4NO is a normally open switch. When zone thermostat calls for heat, it is closed to actuate the pump.
3. Terminals 3 & 4NC is a normally closed switch. When zone thermostat calls for heat, it is open.
4. Terminals 5 & 6NO is a normally open switch. When zone thermostat calls for heat, it is closed.
5. Terminals 5 & 6NC is a normally closed switch. When zone thermostat calls for heat, it is open.
6. Terminals R/T & G/T are inputs from thermostat. The relay is energized when zone thermostat calls for heat.
7. Terminals C - (common) together with R/T (hot) produce 24VAC output to power up additional load (any device with low current rating).

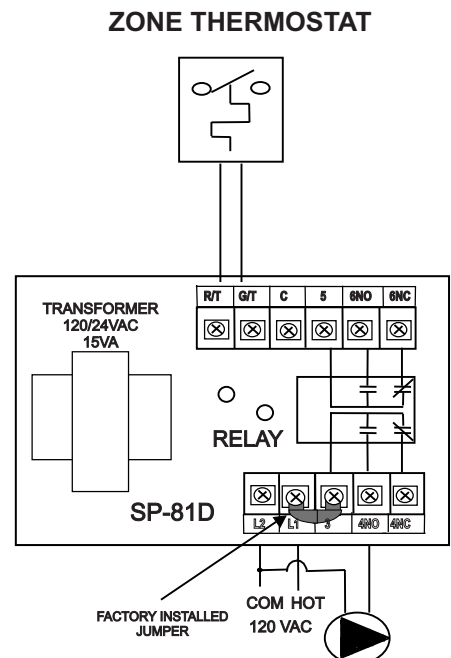

SPEEDPUMP SP-82P/SP-83P SWITCHING RELAYS WITH PRIORITY FOR HYDRONIC HEATING SYSTEMS

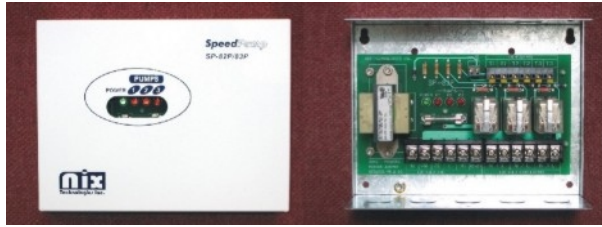

General Applications:

The SP-83P, three zone pump controller is operated by low voltage thermostats or any other low voltage controllers having an SPST switching action. The SP-83P provides intermediate switching to permit up to three separate line voltage loads such as pumps.

The panel provides EZ screwless terminal blocks for connections to the thermostats.

SP-82P, two zone model is also available.

PRODUCT FEATURES AND BENEFITS:

- Field selectable Priority Zone
- Common 24VAC transformer terminal
- High Quality Electronics Circuit Board which Centralizes Wiring and Control Operation
- Status indicator lights visible through the front cover
- Plug-in/Removable Relays with Relays Clamp
- Designed for cold start or tankless coil applications
- High Capacity Transformer
- Easy-Connect Terminals/Screwless Terminals for Thermostat Connections
- Compatible with Most Digital/Mechanical Thermostats
- Fuse Protection
- CSA/NRTL (National Recognized Testing Laboratory) Certified
- 2 Year Guarantee

Model	Relay Switching Action	Thermostat Current	Transformer Rating (nominal)	Single Phase Motor Rating for Each Zone		Dimension L x W x H	Shipping Weight
				120V	240V		
SP-82P SP-83P	DPST	0.18A	120/24VAC 60Hz 15VA	1/3hp (10A)	1/2hp (10A)	8" x 6" x 3" (20.3cmx15.2cmx7.6cm)	3.5lbs. (1.58 kg.)

L.E.D. SYSTEM STATUS INDICATION LIGHTS:

RED light indicates thermostat calling for heat of individual zone.

GREEN light indicates presence of power supply.

NOTE:

When the priority Zone 1 is activated and Zone 1 is calling for heat, the RED lights for Zone 2 and Zone 3 will stay on if that they are calling for heat. However, the circulators for Zone 2 and Zone 3 will be turned off.

WIRING CONNECTIONS:

24VAC	24VAC Transformer Hot	L	120VAC Hot Input
COM	24VAC Transformer Common	X1	Dry Contact End Switch for Cold Start Boiler Application
T1/T1	Zone 1 Thermostat		Different usage for Tankless Coil Application. Refer to wiring diagrams for details.
T2/T2	Zone 2 Thermostat		
T3/T3	Zone 3 Thermostat		
N	120VAC Neutral Input		
PR	To deactivate Zone 1 Priority, simply put a jumper between this terminal and ZC. To activate Zone 1 Priority, simply remove the jumper between terminals PR and ZC.	X2/ZR	Dry Contact End Switch for Cold Start Boiler Application
ZC	Usage depends on Cold start or Tankless Coil Application. Refer to wiring diagrams for details.		Different usage for Tankless Coil Application. Refer to wiring diagrams for details.
	Also work with PR terminal to activate/deactivate Zone 1 Priority.	N 1 L	Zone 1 120VAC Circulator Power
		N 2 L	Zone 2 120 VAC Circulator Power
		N 3 L	Zone 3 120 VAC Circulator Power

WIRING INSTRUCTIONS

COLD START (LOW THERMAL MASS) BOILER APPLICATION

OPERATION

When zone thermostat calls for heat, the appropriate pump is actuated and the isolated end switch (X1-X2) will start the boiler.

JUMPER PLACEMENT

The jumper (factory installed) should be placed between terminal ZC and L. Connect isolated end switch (X1-X2) to T-T terminals on boiler control. To activate Zone 1 Priority, simply remove the jumper between terminals PR and ZC.

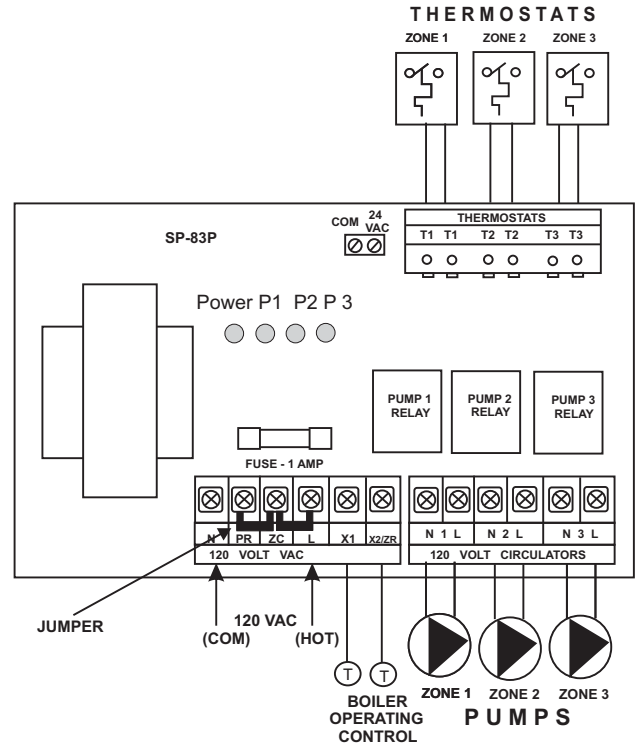

TANKLESS COIL (HIGH THERMAL MASS) BOILER APPLICATION

OPERATION

When zone thermostat calls for heat, the appropriate pump is actuated and the boiler is started. If the boiler temperature drops below the low limit setting, all pumps will cease until the boiler temperature is increased above the low limit.

JUMPER PLACEMENT

Remove the factory installed jumper between terminals ZC and L. Place the jumper between terminals L and X1. Connect terminal ZC to ZC terminal on boiler (aquastat) control. Connect terminal ZR to ZR terminal on boiler (aquastat) control. To activate Zone 1 Priority, simply remove the jumper between terminals PR and ZC.

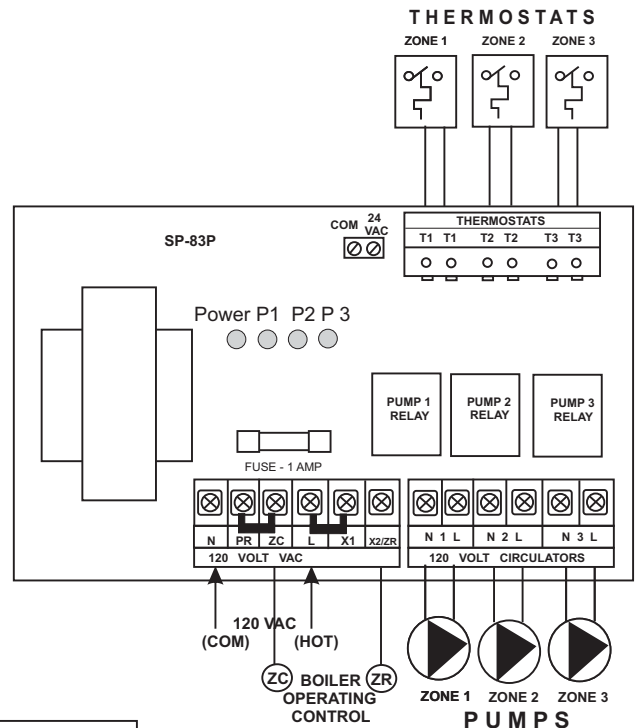

CAUTION!

1. To prevent electrical shock hazard, disconnect power supply before installing.
2. All wiring must comply with national and local electrical codes, ordinances, and regulations. Never connect the load terminals to a load that takes more current than the amount listed for the relay in the electrical ratings.
3. When jumper is placed between terminal L and X1, a line voltage is present between terminal ZC and ZR. Connection of these terminals to low voltage equipment may damage the equipment.
4. NIX Technologies is not responsible for damages resulting from misuse of its products.
5. This literature is provided for informational purposes only.

NIX Technologies Inc.