

Non-Programmable Radiant Floor Digital Thermostat D-26F

A simple, reliable and effective way to sense and control floor temperature

D-26F digital thermostat is specifically designed for Radiant Floor Heating Systems. It is very simple to install and operate without any programming steps. A 10 ft. auxiliary remote sensor is provided to measure and control the slab temperature. In addition, an ON/OFF switch can be used to turn off the relay output. Setpoint and floor temperature or room temperature is displayed on the LCD screen with backlight.

SPECIFICATIONS:

- Display Format: Liquid Crystal Display(LCD) with Backlighting
- Floor Temperature Control Range: 41-113°F(5-45°C)
- Temperature Display Range: 32-140°F(0-60°C)
- Contact Rating: 16A
- Power Supply: 24 Vac, 50-60Hz
- Sampling Rate: 1 Minute
- Accuracy: $\pm 1^{\circ}\text{F}$
- Switching Differential: 0.5/1.0/1.5/2.0 °F/°C
- Dimension: 91.5 x 80.3 x 30 mm
- Resolution: 0.1°F

MODEL	DESCRIPTION
D-26FS	Radiant Floor thermostat with ON/OFF switch

WIRING DIAGRAM:

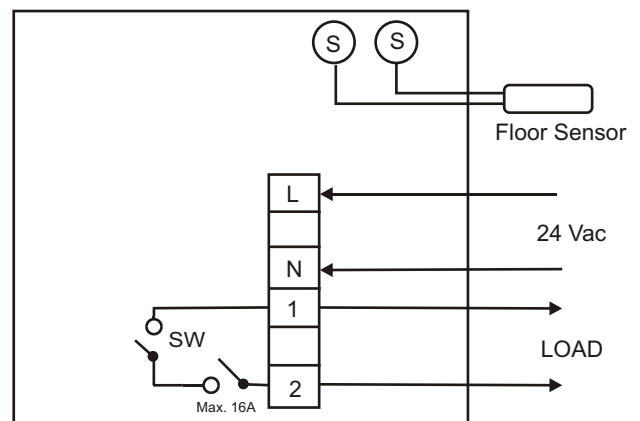

$\pm 1^{\circ}\text{F}$
ACCURACY

Floor Sensor
Included

Easy
View Large
Display



FEATURES:

- Large LCD with backlighting for displaying Setpoint & Floor Temperature or Room Temperature
- Slab Temperature Control for Radiant Floor Heating Systems
- Low Voltage (24 VAC) System
- Reliable Digital Electronic Accuracy
- No Leveling Required
- Contains NO Mercury, environmentally safe
- Only 2 wires needed to power thermostat, no need to change battery in the future
- Selectable display in °F or °C
- EEPROM for setting backup
- ON/OFF switch to shut off relay output
- Supplied with 10ft. floor sensor
- Built-in Digital Control System

AZEL TECHNOLOGIES INC.

For more product information, please visit:
www.azeltec.com

P.O. Box 53138
10 Royal Orchard Blvd.
Thornhill, Ontario, Canada L3T 7R9
Ph: 905-223-5567 Fax: 905-223-3778
Email: info@azeltec.com